

# MALVERNE BUILDING DEPARTMENT APPLICATION

99 Church Street Malverne, NY Phone 516-599-1200 Fax 516-823-0767

## CONCRETE / ASPHALT / PAVERS IN FRONT YARD PERMIT

Incomplete applications will not be accepted.

All fees are non-refundable.

THIS APPLICATION MUST BE ACCOMPANIED BY:

- Two copies of a survey/plot plan indicating areas and sizes of all proposed work, including driveways, aprons, curbs and sidewalks.
- Fee = \$75 for first area/item, \$25 each additional area/item
- See attached diagrams for village mandated specifications of Sidewalks, Aprons, Curbs. Cobblestone or Belgium Block curbs at the street are not permissible. No more than one curb cut per Residential Property.
- Cement and/or Concrete wash-out shall not be dumped into storm drains or streets.
- Landings, steps, retaining walls, terraces over 8 1/4" above the ground shall be filed under a building permit application. On grade walkways within the property, on grade patios in rear yards, etc. do not require a permit but are required to adhere to all applicable zoning codes.
- Inspection is required prior to pouring concrete. Please notify the Building Department at 516-599-1200 extension #113 or #114 48 hour notice is required. All concrete work requires a copy of the concrete pour ticket - permit cannot be closed until received.
- 600-4.1 J. Off Street Parking: The total area of driveway, parking space, pavement, gravel or combination thereof in the front yard of a dwelling that is intended and used for the parking of vehicles shall not exceed the amount of square footage derived by multiplying the shortest distance in feet between the front line of the plot and the nearest point of the building by 20.

Date: \_\_\_\_\_

Permit / App # \_\_\_\_\_

Owner Name: \_\_\_\_\_ Phone # \_\_\_\_\_ Email: \_\_\_\_\_

Address of Project: \_\_\_\_\_ Malverne, NY 11565

Check all that apply: Residential \_\_\_\_\_ Commercial \_\_\_\_\_ As Built \_\_\_\_\_ New \_\_\_\_\_

Concrete Sidewalk: \_\_\_\_\_ Linear Feet \_\_\_\_\_  
Concrete Curb: \_\_\_\_\_ Linear Feet \_\_\_\_\_  
Concrete Corner Curb: \_\_\_\_\_ Dimensions \_\_\_\_\_ x \_\_\_\_\_ (Must Include Handicap Ramp)

Driveway: \_\_\_\_\_  
Dimensions (existing size) \_\_\_\_\_ (proposed size) \_\_\_\_\_

Driveway Material: Pavers \_\_\_\_\_ Brick \_\_\_\_\_ Concrete \_\_\_\_\_ Blacktop/Asphalt \_\_\_\_\_ Gravel \_\_\_\_\_

Concrete Apron: \_\_\_\_\_  
Dimensions (existing size) \_\_\_\_\_ (proposed size) \_\_\_\_\_

Other (specify): \_\_\_\_\_

Contractor Name: \_\_\_\_\_ Malverne License # \_\_\_\_\_

Phone: \_\_\_\_\_ Email: \_\_\_\_\_

Signature of Contractor

Signature of Property Owner (notarized)

Village Approval Signature and Stamp

Sworn to before me this \_\_\_\_\_ day of \_\_\_\_\_

NOTARY SIGNATURE \_\_\_\_\_

SEAL:

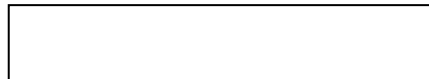

No registered contractor shall sign a concrete/paving permit or act as an agent for a person who is not a licensed contractor in the Village of Malverne. I understand by signing below that my license in the Village of Malverne could be in jeopardy by violating the above section. Applicant certifies that all information given is correct and that all work shall conform to the current NYS Residential, Building, Fire, Existing Building, Property Maintenance and all Village Ordinances for which this permit is issued. No work is to be performed until a permit has been issued by the Incorporated Village of Malverne.

For Office Use Only  
Final Sign off from Inspector

Date: \_\_\_\_\_ Inspector Name: \_\_\_\_\_

# SIDEWALK / APRON / CURB STANDARDS

## VILLAGE OF MALVERNE

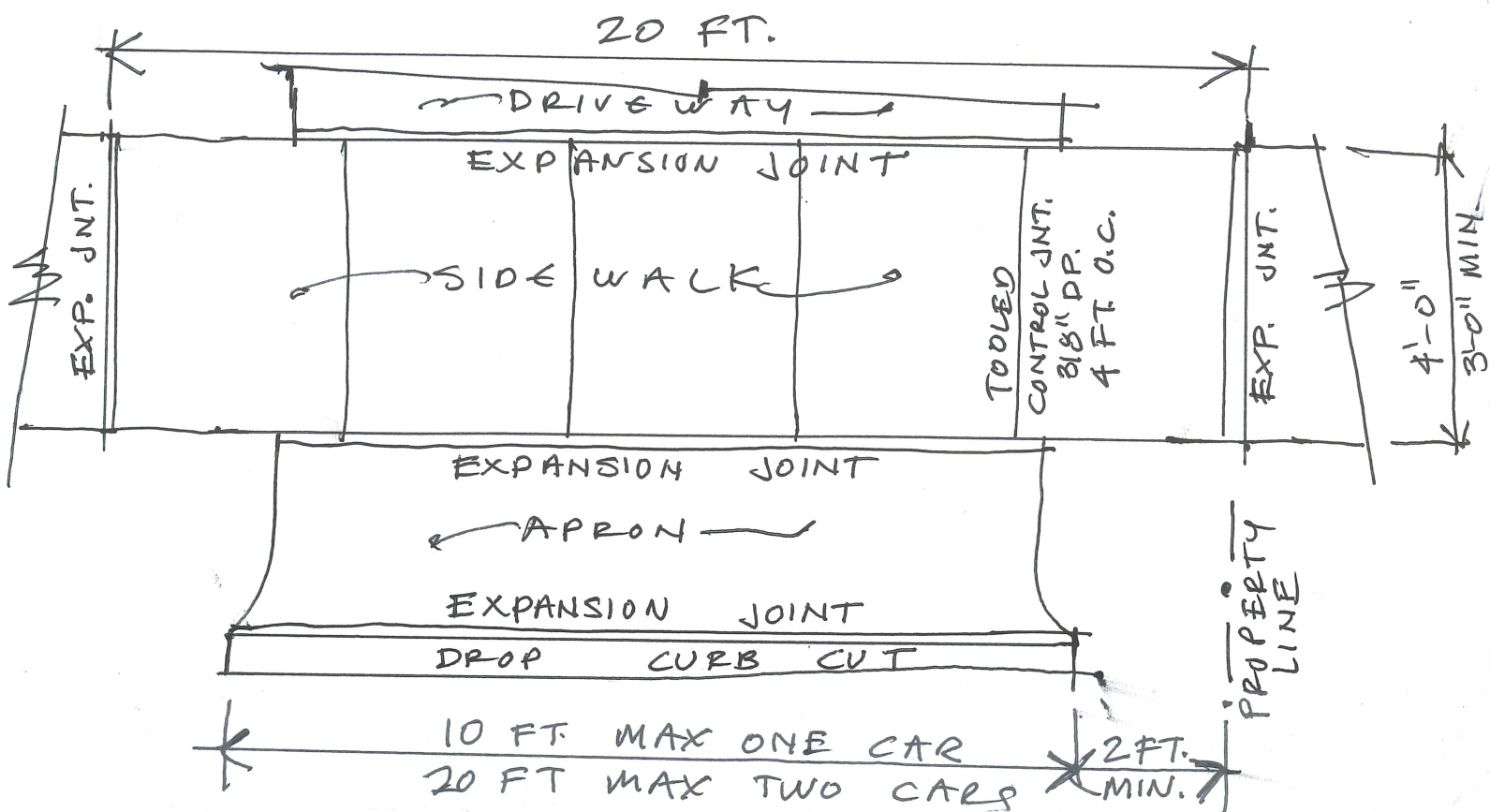

TRAFFIC BEARING CONCRETE = 4000 PSI AND 6" THICK WITH 6x6-W1.4/W1.4 WNM AT SIDEWALKS, APRONS, CURB CUTS. ALL OTHER CONCRETE 3000 PSI AND 4" THICK EXCEPT COMMERCIAL SIDEWALKS 5" THICK - ALL CONCRETE ON COMPACTED 4" RCA OR APPROVED EQUAL

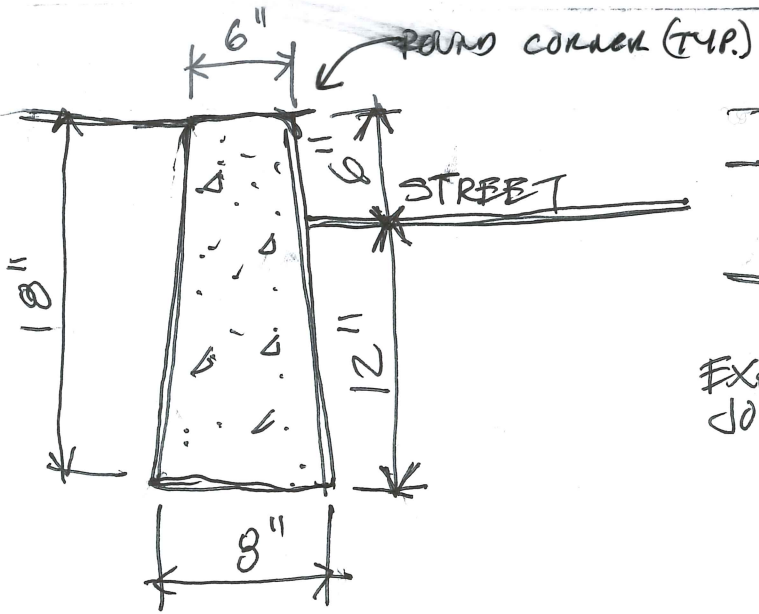

CURB DETAIL

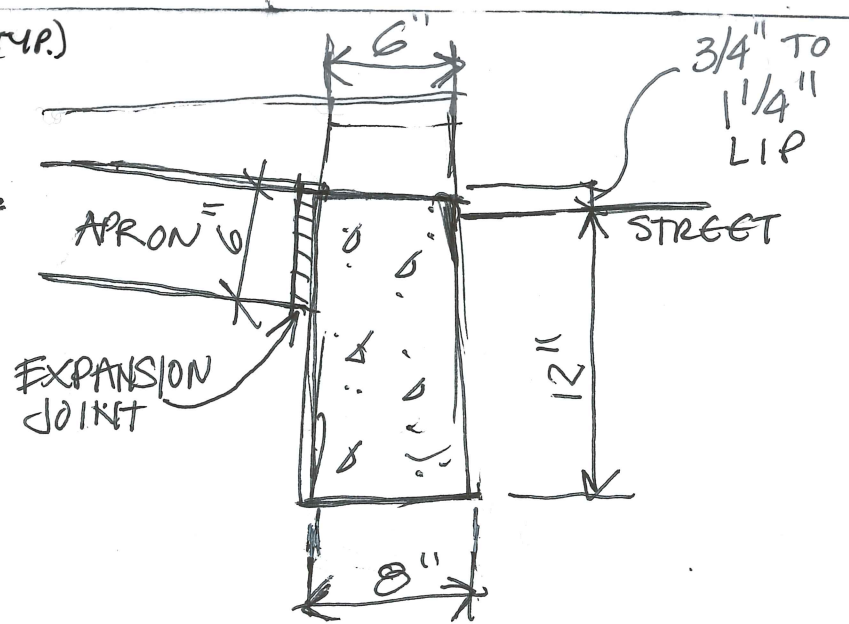

CURB CUT